

KENNEL UNION OF SOUTHERN AFRICA



REGULATIONS FOR FLYBALL

SCHEDULE 5 (M)

Appendix A to E

Scope of this Document

This document covers Appendix A through to E, listed below, and must be used in conjunction with Schedule 5 (M), Regulations for Flyball.

1. Appendix A: Jump Diagram.
2. Appendix B: Flyball Arena Set-up.
3. Appendix C: Round Robin and Knockout explanation.
4. Appendix D: Team and Score sheets
5. Appendix E: Officials Guidelines (Quick Reference)

Compiled by: R. Shortland and N. McInnes
Date: 28.10.2003

APPENDIX A

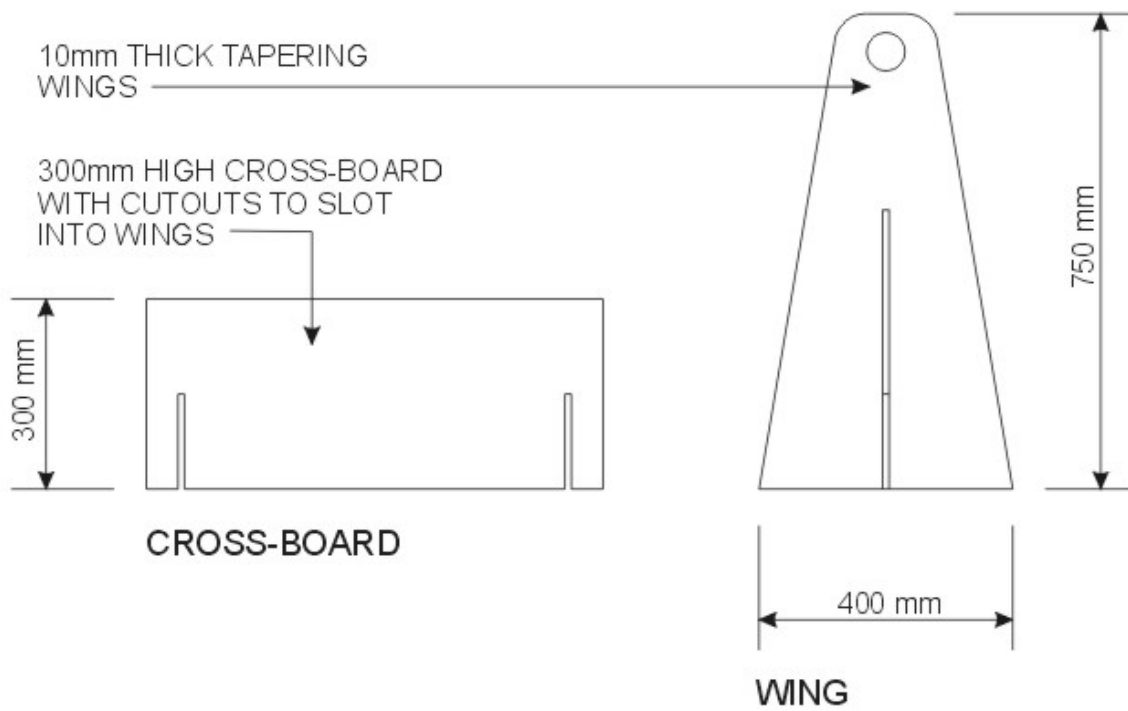
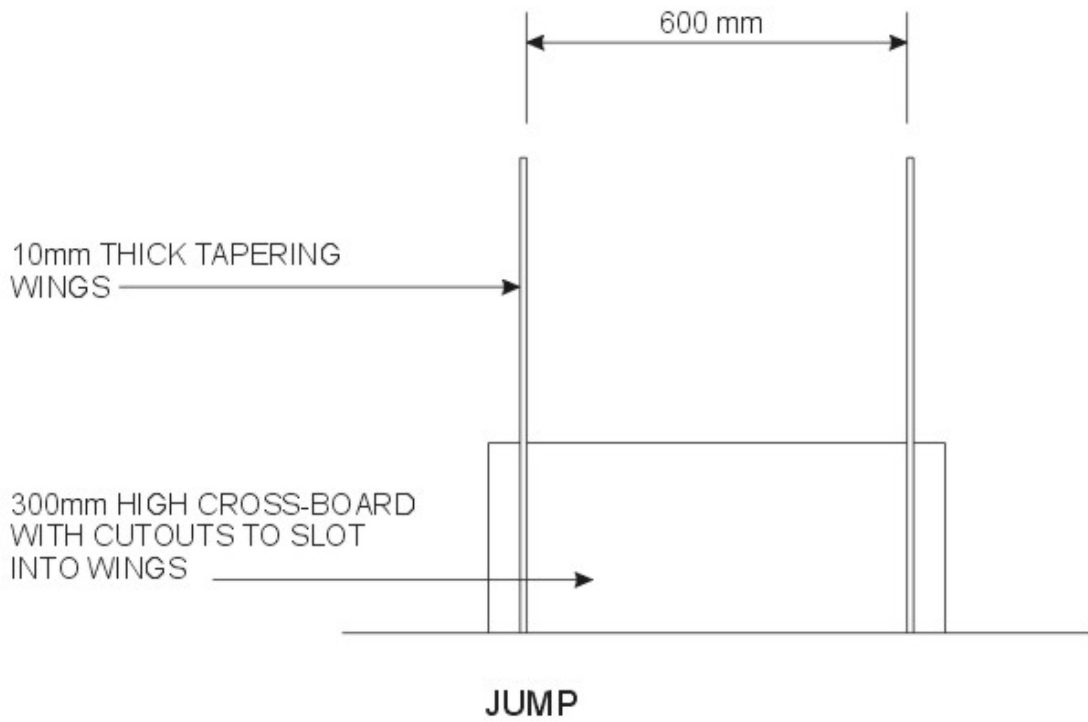

APPENDIX B

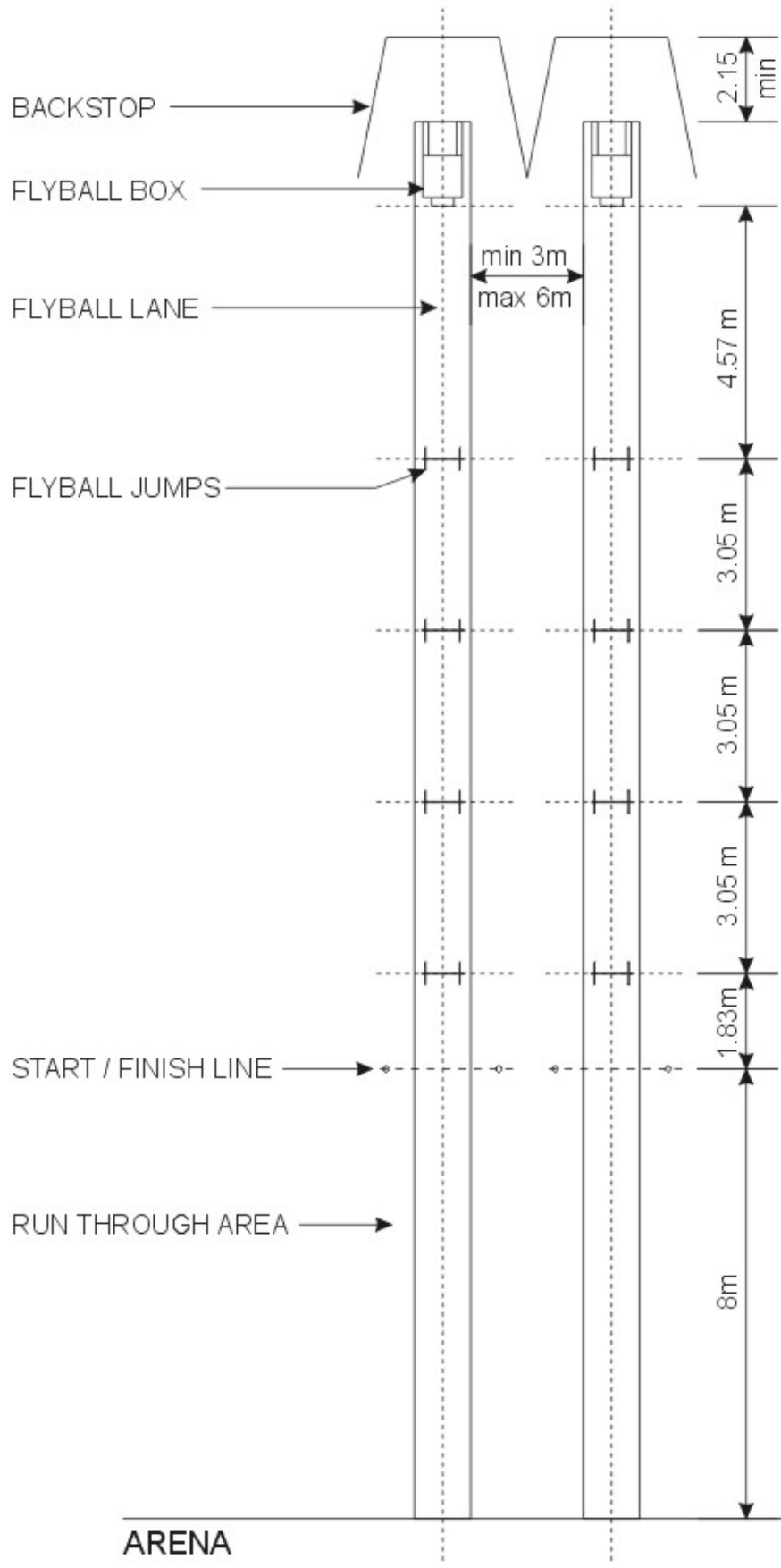

APPENDIX B

CONTINUED

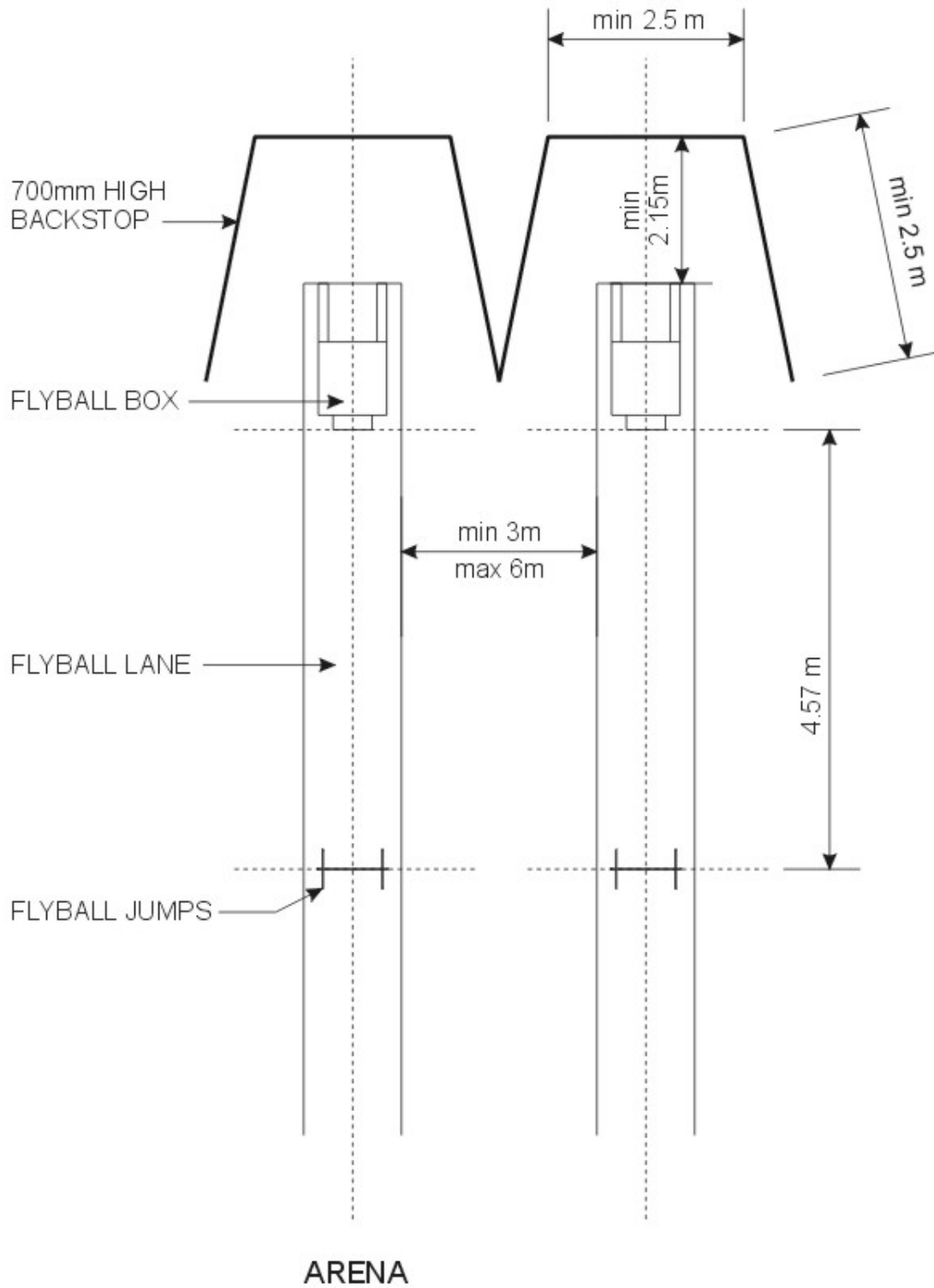

Appendix C

Round Robin (Regulation 12.1)

Race Order:

Four teams entered each team will run three times, for five teams entered each team would run four times and so on..... as follows:

4 TEAM ROUND ROBIN

RACE 1 - 4 vs 1
RACE 2 - 2 vs 3
RACE 3 - 1 vs 3
RACE 4 - 4 vs 2
RACE 5 - 3 vs 4
RACE 6 - 1 vs 2

5 TEAM ROUND ROBIN

RACE 1 - 5 vs 2
RACE 2 - 4 vs 1
RACE 3 - 3 vs 5
RACE 4 - 2 vs 4
RACE 5 - 1 vs 3
RACE 6 - 4 vs 5
RACE 7 - 2 vs 3
RACE 8 - 5 vs 1
RACE 9 - 3 vs 4
RACE 10 - 1 vs 2

Scoring System:

Team 'C' wins the competition.

Team 'C' score sheet:

Team C	Heat 1	Heat 2	Heat 3
Race One	23.52	24.52	23.25
Race Two	24.62	26.35	24.15
Race Three	23.23	24.66	23.89

Therefore the winning time would be from Race 3, Heat 1 at 23.23 sec. giving each dog in Team 'C', according to the points system, regulation 6.1, 15 points.

Knockout (Regulation 12.2)

Race Order, 10 team example:

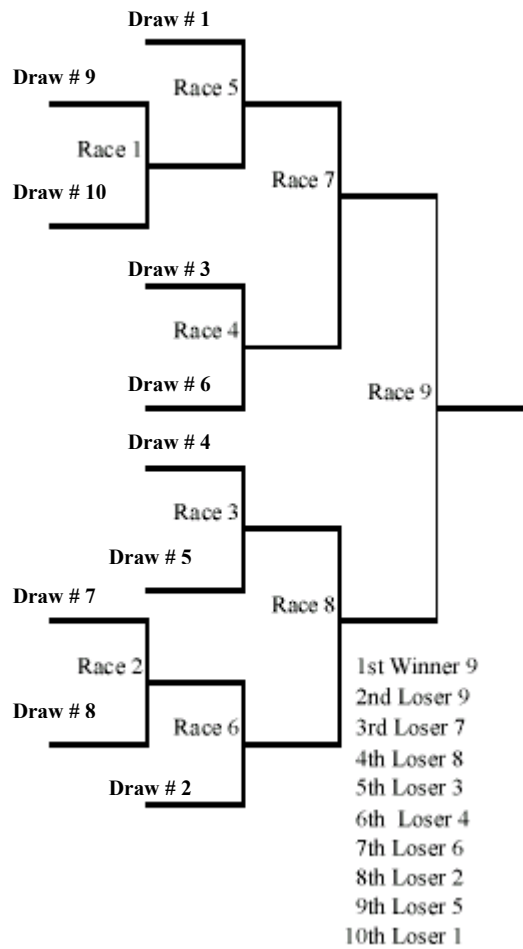

Allocation of points toward Championship Status:

Once a team has won, the winning race time of that team from the final Heat will be taken towards the points for Championship Status

Appendix D (1)

Team Sheet

Event Name:	
Date:	
Judge:	

Team Draw:		Team Name:	
Team Captain:			
Team Members	Dogs Name	Handlers Name	
Dog 1			
Dog 2			
Dog 3			
Dog 4			
Reserve			
Reserve			

Team Draw:		Team Name:	
Team Captain:			
Team Members	Dogs Name	Handlers Name	
Dog 1			
Dog 2			
Dog 3			
Dog 4			
Reserve			
Reserve			

Team Draw:		Team Name:	
Team Captain:			
Team Members	Dogs Name	Handlers Name	
Dog 1			
Dog 2			
Dog 3			
Dog 4			
Reserve			
Reserve			

Team Draw:		Team Name:	
Team Captain:			
Team Members	Dogs Name	Handlers Name	
Dog 1			
Dog 2			
Dog 3			
Dog 4			
Reserve			
Reserve			

Appendix D (2)

Round Robin Scoresheet

Team No.:		vs	Team No.:	
Race Number:				
Heat No.:		Time		Time
Heat 1				
Heat 2				
Heat 3				
Winner:				
Points:			1	
Loser:				
Points:			0	

Team No.:		vs	Team No.:	
Race Number:				
Heat No.:		Time		Time
Heat 1				
Heat 2				
Heat 3				
Winner:				
Points:			1	
Loser:				
Points:			0	

Team No.:		vs	Team No.:	
Race Number:				
Heat No.:		Time		Time
Heat 1				
Heat 2				
Heat 3				
Winner:				
Points:			1	
Loser:				
Points:			0	

Team No.:		vs	Team No.:	
Race Number:				
Heat No.:		Time		Time
Heat 1				
Heat 2				
Heat 3				
Winner:				
Points:			1	
Loser:				
Points:			0	

Team No.:		vs	Team No.:	
Race Number:				
Heat No.:		Time		Time
Heat 1				
Heat 2				
Heat 3				
Winner:				
Points:			1	
Loser:				
Points:			0	

Team No.:		vs	Team No.:	
Race Number:				
Heat No.:		Time		Time
Heat 1				
Heat 2				
Heat 3				
Winner:				
Points:			1	
Loser:				
Points:			0	

Team No.:		vs	Team No.:	
Race Number:				
Heat No.:		Time		Time
Heat 1				
Heat 2				
Heat 3				
Winner:				
Points:			1	
Loser:				
Points:			0	

Team No.:		vs	Team No.:	
Race Number:				
Heat No.:		Time		Time
Heat 1				
Heat 2				
Heat 3				
Winner:				
Points:			1	
Loser:				
Points:			0	

Team No.:		vs	Team No.:	
Race Number:				
Heat No.:		Time		Time
Heat 1				
Heat 2				
Heat 3				
Winner:				
Points:			1	
Loser:				
Points:			0	

Team No.:		vs	Team No.:	
Race Number:				
Heat No.:		Time		Time
Heat 1				
Heat 2				
Heat 3				
Winner:				
Points:			1	
Loser:				
Points:			0	

Appendix D (3)

Round Robin Points Sheet

Team No.:	
Team Name:	
Number of Races	Points Scored

Team No.:	
Team Name:	
Number of Races	Points Scored

Team No.:	
Team Name:	
Number of Races	Points Scored

Team No.:	
Team Name:	
Number of Races	Points Scored

Team No.:	
Team Name:	
Number of Races	Points Scored

Team No.:	
Team Name:	
Number of Races	Points Scored

Team No.:	
Team Name:	
Number of Races	Points Scored

Team No.:	
Team Name:	
Number of Races	Points Scored

Team No.:	
Team Name:	
Number of Races	Points Scored

Team No.:	
Team Name:	
Number of Races	Points Scored

Team No.:	
Team Name:	
Number of Races	Points Scored

Team No.:	
Team Name:	
Number of Races	Points Scored

Team No.:	
Team Name:	
Number of Races	Points Scored

Team No.:	
Team Name:	
Number of Races	Points Scored

Placing	Team No.:	Team Name	Points
1 st			
2 nd			
3 rd			
4 th			
5 th			
6 th			
7 th			
8 th			
9 th			
10 th			
11 th			
12 th			
13 th			
14 th			

Appendix D (4)
Knock-out Scoresheet

D/No.:		Team:	
--------	--	-------	--

Heat 1	
Heat 2	
Heat 3	

Team:	
-------	--

D/No.:		Team:	
--------	--	-------	--

Heat 1	
Heat 2	
Heat 3	

Team:	
-------	--

D/No.:		Team:	
--------	--	-------	--

Heat 1	
Heat 2	
Heat 3	

Team:	
-------	--

Time:	
Heat 1	
Heat 2	
Heat 3	

D/No.:		Team:	
--------	--	-------	--

D/No.:		Team:	
--------	--	-------	--

Heat 1	
Heat 2	
Heat 3	

Team:	
-------	--

D/No.:		Team:	
--------	--	-------	--

Heat 1	
Heat 2	
Heat 3	

Team:	
-------	--

D/No.:		Team:	
--------	--	-------	--

Heat 1	
Heat 2	
Heat 3	

Team:	
-------	--

Time:	
Heat 1	
Heat 2	
Heat 3	

D/No.:		Team:	
--------	--	-------	--

Team:	
Time:	

Team:	
Time:	

Appendix E

Flyball Schedule 5M **Officials Guidelines (Quick Reference)**

Judges Guidelines

General

- (a) Give a warning if:
 - (i) it is not a clear violation; or
 - (ii) if the other team has completed the race and is a clear winner.
- (b) Flags should be held up sufficiently so the team has an opportunity to note the penalty.
- (c) Judges and/or Stewards are not obligated to advise teams when a dog is to run again, nor are they obligated to explain a decision.

Stopping a race (indicate with a whistle)

- (a) For interference.
- (b) If a dog fouls in the ring.
- (c) If the box loader indicates the box has malfunctioned.

Restarting a race

If the box malfunctions (first time only for any one heat).

When a team would forfeit the heat

- (a) For the second time a box malfunctioned in any one heat or if the Judge determines the box did not malfunction.
- (b) If a dog fouls in the ring.
- (c) Interference.

When dogs must race again (indicate with a signal)

- (a) For an illegal pass.
- (b) If the dog:
 - (i) misses one or more jumps;
 - (ii) fails to carry the ball over the start/finish line;
 - (iii) takes the ball from the cup;
 - (iv) does not trigger the box.
- (c) If the dog is aided by other than verbal assistance (i.e. by a spectator or a handler). The dog is not to be penalised for retrieving a ball from out of bounds/play unless aided.
- (d) If the handler crosses the start/finish line (other than to retrieve a loose ball or set up a knocked down jump).

Judge's responsibilities

- (a) Inspect boxes and the ring set-up prior to racing.
- (b) Check with each Steward and team prior to the start of each race.
- (c) Start and stop the races. The race is not over until the Judge declares a winner.
- (d) Observe handlers for possible violation (bouncing tennis balls or otherwise distracting the other teams).
- (e) Get into position to observe the finish without distracting either team.
- (f) Confer with the Line Stewards and Box Stewards following each heat.
- (g) Declare a winner and indicate to the teams and spectators who is the winner.
- (h) Notify the announcer of the outcome of the heat (if one is present).
- (i) Check the time sheets following each heat.
- (j) Sign the time and judges sheets following the competition.

ScoreKeeper

- (a) Draw for race order.
- (b) Allocated race lanes as per regulation 8.13.1, Schedule 5M
- (c) Record the dogs racing, times and the winning teams.

Lane Steward's responsibilities

- (a) Confer with the Judge following each heat to determine the winning team.
- (b) Observe or indicate false starts, illegal pass, or if the handler crosses the start/finish line in assigned lane.
- (c) Observe the dogs for interference (forfeit), fouling in the ring (forfeit) or missing a jump (dog is to run again).

Box Steward's Responsibilities

- (a) Observe that the box loader or spectators do not assist the dog racing.
- (b) Inspect, along with the judge, any box that malfunction (box loader to indicate to the box Steward if the box malfunctioned).